



PW-400

Cardboard and Tray skin Packaging Machine



Searching for a New Balance

Dimensions

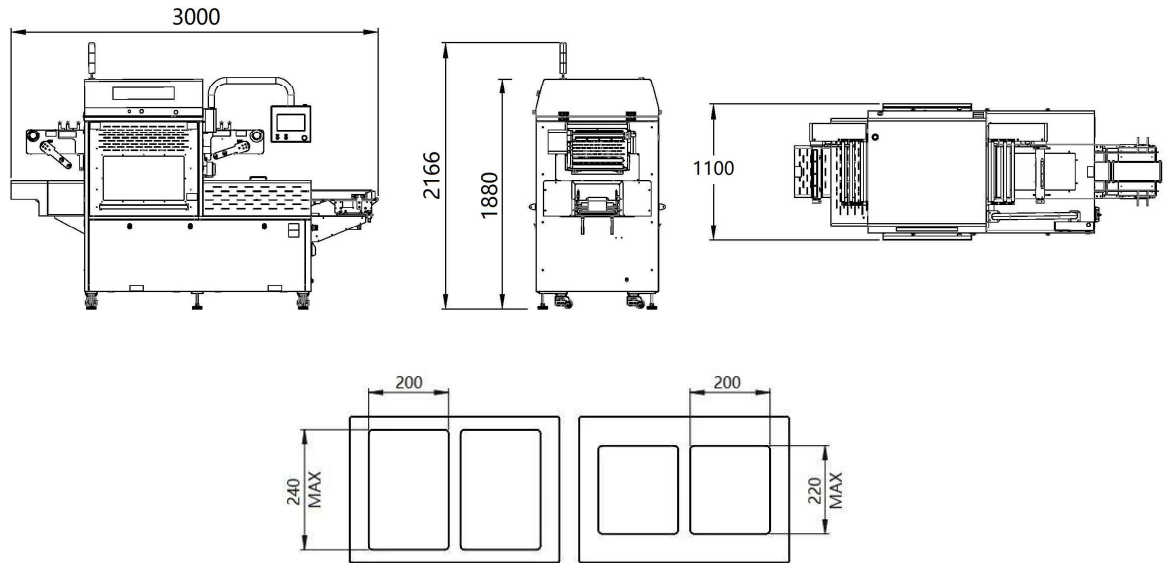

Tray / Cardboard Layout

Specifications

| | | | |
|--|--|---|---|
| Packaging Type | Skin Packaging | Film Material | Skin Film |
| Packaging Item | Tray and Cardboard | Film Width(mm) | 340~390 |
| Cycle time(Second) | 20~25 | Film Thickness(um) | 100 |
| Packaging Speed(PCS/Hour) | 290~360 | Diameter of Film Roll(mm) | Max. 260 |
| Power Supply | AC 380V, 50Hz/60Hz | Core Diameter of Film Roll(mm) | 76 |
| Power Consumption(kW) | 10 | Size of Tray/Cardboard Two Cavities (W x L mm) | Max. 200 x 240 |
| Gas Supply(MPa) | 0.6~0.8 (Air compressor integrated) | Max.packing height of Cardboard(mm) | 30 |
| Machine Weight(kg) | 1044 | Max.packing height of Tray (mm) | 70 (Max.deep of tray 40+ Max.protruding surface 30) |
| Overall Dimension of Machine (L x W x H mm) | 3000 x 1100 x 2166 | Machine Height When Cover Opens(mm) | 2520 |

Option

Automatic Weigh-Label system



LI-5600A



LI-5600C

*Specifications are subject to change without prior notice.

SHANGHAI TERAOKA ELECTRONIC Co., Ltd.

TINGLIN INDUSTRY DEVELOPMENTAL ZONE,
JINSHAN COUNTY, SHANGHAI 201505
TEL: +86-21-57234888
FAX: +86-21-57233049
<http://www.digisystem.com.cn>